

Honduras-Norway Fireproof Cable Trays

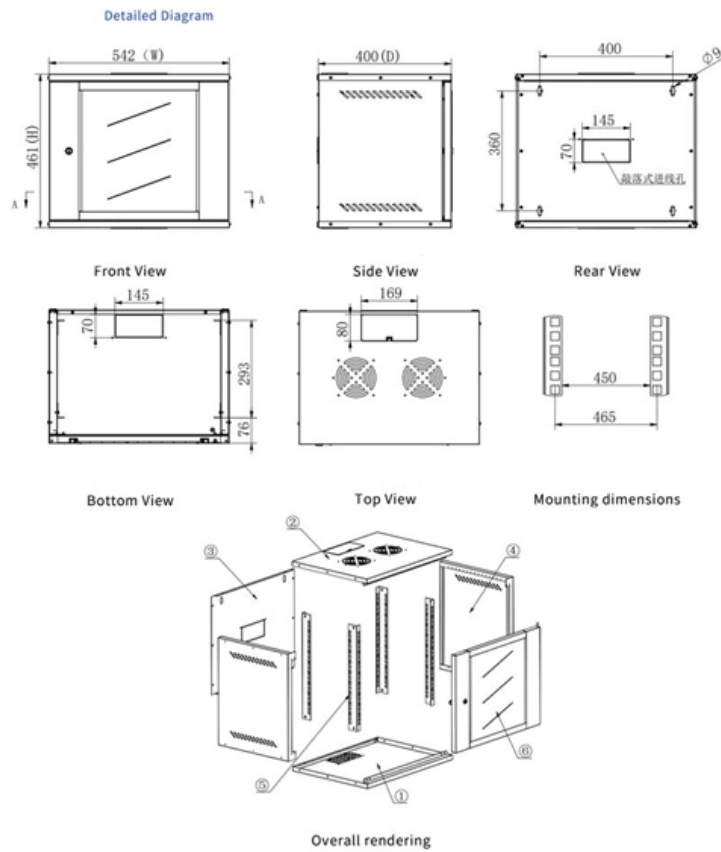



Honduras-Norway Fireproof Cable Trays

Fire Resistance Testing of Cable Trays: Key Standards

Are Your Cable Trays Fireproof? Here's How to Find Out When a fire breaks out, the last thing you want is your cable trays fueling the flames. But how

CSD Sealing Systems: Firestops

CSD FIRSTO® firestops are designed to seal multi-cable and cable tray penetrations of fire-rated walls or floors. FIRSTO® utilizes a metal frame that encompasses



How do cable trays perform in fire conditions?

How do cable trays perform in fire conditions? To uncover the answer to this question, we have conducted tests on cable tray systems in different materials.

Cable trays

Our cable trays are produced in fit for purpose materials like stainless steel, galvanized, aluminium and fibreglass (FRP/GRP) composites to suit any project

Cable Trays In Honduras

We, the renowned Electrical Cable Trays Manufacturer and Supplier in Honduras, use premium materials like galvanized steel, stainless steel, and fiberglass to manufacture our cable trays. We



Cable Trays System

Cabel trays, fittings, barrier strips, covers, accessories 5 Items Show 25 50 75 100 per page Sort By Cable Trays in various edge heights Edge Height 35 Edge Height 50 Edge Height 60 Edge Height 85

Fire protection for cables & cable trays , Flamro

The mostly combustible cable sheaths and insulation allow a fire to spread along the cable at rapid speed. Our tested solutions for cable fire protection can delay the

Cable Trays, certified solutions for the support and

> Usable also in Hazardous Locations. > Wide range of fittings and accessories. Learn



more about the technical aspects of the product. > Wire mesh

Fireproof Spray Cable Tray 84 - gilautomation

The fireproof cable tray has the functions of heat insulation, flame retardant and anticorrosion at high temperature. the pre-painted cable tray has anti-static, oil-resistant, waterproof and anti-corrosion

Technical Guidelines for Cable Tray Installation and

Periodically inspect outdoor trays for rust, moisture accumulation, or UV damage reproof trays require scheduled inspection for coating integrity and



Fireproof Spray Cable Tray 89 - gilautomation

The fireproof cable tray has the functions of heat insulation, flame retardant and anticorrosion at high temperature. the pre-painted cable tray has anti-static, oil

US4276332A

Other investigators have attempted to provide cable tray systems which provide fire protection for extended periods of time, i.e., in excess of 15 minutes. Most have concentrated on systems which

Fireproof Channel Cable Tray System

The fireproof channel cable tray system is produced by galvanized channel cable tray after processing surface treatment of a layer of fireproof coating. In addition,



Eurostrut Cable Trays , cable tray, cable route and

Cable trays for industrial and marine use. Includes distribution trays, cable routes and NATO-type models. Request a quote directly via our webshop.

Fire protection for cables & cable trays , Flamro

The mostly combustible cable sheaths and insulation allow a fire to spread along the cable at rapid speed. Our tested solutions for cable fire protection can delay the spread of fire in order to minimise

Firsto System , CSD Sealing Systems

FIRSTO is specifically suitable for the fire resistant ducting of cables and/or cable trays



through wall and floor penetrations. No other firestop can offer the high level

Cable trays

We offer a wide range of cable tray systems to support tubing, electrical cables and instrumentation. Our cable trays are produced in fit for purpose materials like

The Essential Guide to Fireproof Cable Trays: Ensuring Safety in

Fireproof cable trays are a vital component in electrical installations, designed to support and protect electrical cables while minimizing the risk of fire hazards. These trays are constructed



UNIFRAX Fyrewrap fireproof Coating for Cables, Cable

Our company's cable insulation, cable tray, and pipeline fireproof materials adhere to the global standards recognized by FM (Factory Mutual Insurance Company).

Fire-Resistant Cable Support Systems

Meka Pro regularly tests the fire resistance of its products to ensure high-quality and safe cable management systems. The products are tested extensively and using

Cable Trays

Cable Trays and Cable Management Systems A cable tray is an essential component in electrical systems, providing a structured pathway for safely routing



Leading Cable Tray Manufacturers In Honduras

Cable Trays are important for ensuring the protection of the wiring system and supporting insulated electric cables used for distribution and communication. Brilltech Engineers Pvt. Ltd is one of the

Cable Tray Covering & Fire Protection

Build fire-rated enclosures around tray runs, transitions, and penetrations to block flame and smoke movement. Integrate coverings with existing fireproofing and firestopping systems for full compliance

Cable Trays



Cable Trays Cable tray is a system used to safely carry and protect electrical cables along pathways planned specifically for building and facility installations.

Fireproof Spraying for Cable Trays: Enhance Safety

Discover top-quality fireproof spraying cable trays for enhanced safety and reliability. Ideal for industrial and commercial applications. Ensure your cables are

Fire resistant cable tray , Hermi-solutions

Cable trays are intended for the construction of fire-resistant cable paths. Do you need help with your purchase? The HERMI team will be happy to advise you and



Fireproof Cable Trays 300*100 Galvanized Trough Type Metal

Our main products are electrical cable, Cable Tray, We have more than 15 production lines which can produce customize according to your requirements. We ensure product quality through systematic

PVC Cable Tray In Honduras

Our trays can be easily cut, drilled, and joined using appropriate tools, allowing for flexible configuration on-site. We, the foremost Perforated Cable Tray Manufacturer and Supplier in Honduras, offer a wide

Fire-Resistant Cable Trays in High-Risk Environments

Explore the importance of fire-resistant cable trays in high-risk environments. Learn



about the best materials and practices to

Contact Us

For datasheets, pricing, or custom optical networking solutions, please visit:
<https://www.entrenamientointeligente.es>