

Mauritius Explosion-proof Distribution Box Installation Company

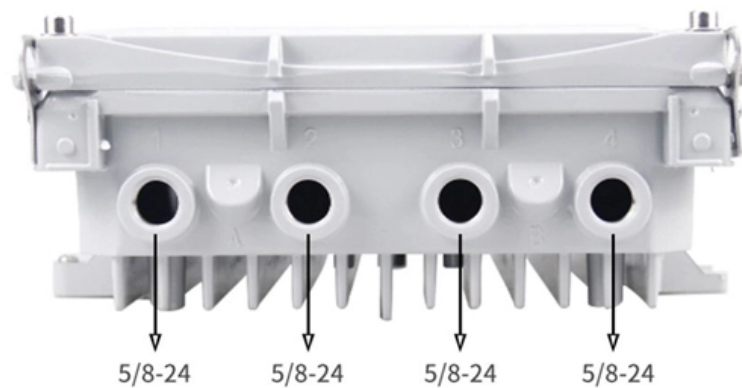



Mauritius Explosion-proof Distribution Box Installation Company

Explosion Proof Box & Cabinet

Product features: The explosion-proof control cabinet (box) can install various instruments inside. Low-voltage electrical appliances, frequency converters, PLCs, soft starters, and computer systems can

Explosion Proof Certification , SGS Mauritius

Explosion proof certification services from SGS - opening the door to the global market for equipment intended for use in explosive atmospheres.



Energy Distribution

BARTEC offers one of the most extensive ranges of explosion-proof and substance-resistant components, devices, and systems for controlling, switching, and

Spexa Electrical

At Spexa Electricals, our goal is to deliver innovative, reliable, and certified explosion-proof solutions that enhance safety and performance across the oil and

Design & Engineering

Systems Building is a company based in Mauritius since 1974, specialising in design, installation and maintenance of electrical and mechanical engineering services for the building industry.



Ex junction and terminal boxes - Explosion-Proof , mlx-ex

GRP Ex terminal boxes What are Ex Terminal Boxes? Ex terminal boxes are protective enclosures used to connect and distribute electrical circuits safely within explosive atmospheres. They serve as

Mauritius

ABOUT US Since its foundation in 1987, Box Manufacturing has been committed to meet the needs of clients in terms of packaging and giveaways. We also produce

Lumitech Ltee Electrical Contractor Mauritius



In such projects, our in-house services include engineering and project management from concept to site construction, fabrication, installation and commissioning of

Explosion-Proof Distribution Boxes & Panels Manufacturer

The explosion-proof distribution box safely delivers power in hazardous zones (oil, gas, chemical plants) with rugged, spark-resistant casing--ATEX/IECEX, IP66 certified for reliable operation in explosive

Explosion proof Power Distribution Panel Box

Power Distribution panel box - Hazardous locations for explosive gas mixtures: Zone 1 and Zone 2. Explosive gas mixtures: Class IIA, IIB, and IIC.



Distribution Boxes in Mauritius , Breaker Enclosures

Shop high-quality distribution boxes and enclosures for circuit breakers at Electrical.mu. Designed for safety and durability, our range includes solutions for residential, commercial, and industrial electrical

Electrical

Ensure the electrical installations during your construction project with a wide range of electrical accessories, home automation and lighting solutions at CMH.

Explosion Proof Certification , SGS Mauritius

Our unrivaled experience, expertise and resources make us the first choice for clients looking to achieve explosion proof certification across the globe. Contact your local SGS office to find out more about



How to Install Explosion-Proof Distribution Box

3. Regularly inspect the explosion-proof distribution box for any damage to components. The installation inclination of the distribution box should

Systems Building Mauritius - Design, installation and maintenance

Systems Building is a company based in Mauritius since 1974, specialising in design, installation and maintenance of electrical and mechanical engineering services for the building industry.

Explosion-Proof Electrical Distribution Boxes:



Applications in

An explosion-proof distribution box is a specialized enclosure designed to contain internal explosions and prevent the escape of flames, sparks, or hot gases. It is essential to note that these boxes are

Terminal boxes , Junction boxes , Ex , Ex e , Ex d , ATEX , Explosion

Safely conduct, connect and distribute energy in hazardous areas with R. STAHL's terminal boxes. We offer bespoke, custom-made terminal boxes and terminal box combinations, as well as standard

Explosion Proof Enclosure Comprehensive Guide

Explosion-Proof Distribution box: These smaller components are structurally similar to distribution cabinets. You can use these for the distribution



Installation

Systems Building is a company based in Mauritius since 1974, specialising in design, installation and maintenance of electrical and mechanical engineering services

How to Wire an Explosion-Proof Distribution Box and

Explosion-proof electrical equipment, such as explosion-proof distribution boxes, is specifically designed for hazardous environments where flammable gases,

Contact Us

For datasheets, pricing, or custom optical networking solutions, please visit:
<https://www.entrenamientointeligente.es>