

Ning an Power Distribution Box

STAINLESS STEEL WIRE MESH

Long-lasting and durable

Comprehensive specifications

Customized non-standard products

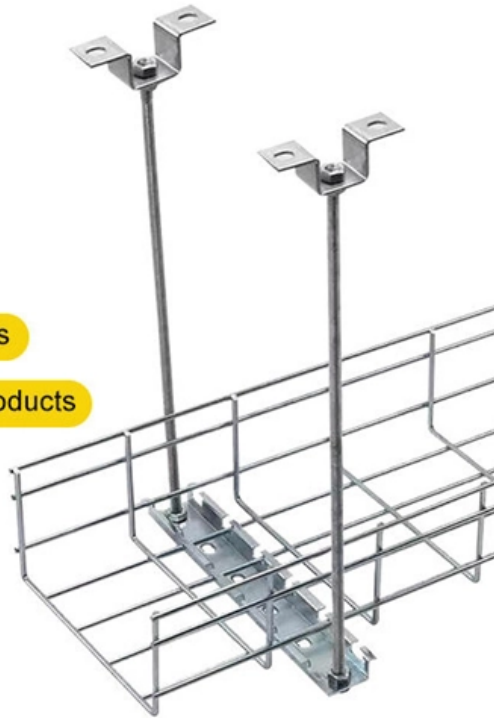



Understanding a Power Distribution Box

Distribution Boxes Explained: Types, Functions, and

Learn about distribution boxes, their types, functions, and safety features to ensure efficient and secure electrical power distribution in any building.

Distribution Box Installation: A Complete Guide to Safe

The distribution box, often referred to as a breaker box, fuse box, or electrical panel, is a critical component of any electrical system. It acts as the central hub for



Power Distribution Boxes Explained Simply

Learn what a power distribution box is, how it works, key components, types, and why it's vital for safe and efficient electrical systems.

Understanding Power Distribution Boxes: Types, Features, and

A power distribution box is an electrical device that distributes electricity from a single source to multiple circuits, ensuring safe and efficient power management.

How Does a Power Distribution Box Work

In this article, we'll walk you through the step-by-step process of how power flows through a distribution box, what components are involved, and why each part is



CHINT Distribution box PZ30-45 Ning assembly power 1.2mm Selling

Buy the CHINT Distribution Box PZ30-45 Ning Assembly Power 1.2mm for secure, reliable, and efficient power distribution. Perfect for residential, commercial, and industrial applications. Easy installation,

Explore Power Distribution Box Types and Functions

In the distribution box, commonly known as the distribution board or breaker panel, you'll find several critical components responsible for managing

What does a power distribution box do ?



During maintenance or repair work on a particular electrical device or circuit, electricians need to ensure that the power to that specific area is turned off. The

How does a power distribution box work

The distribution box is a very important component of the power system. It is responsible for transmitting electrical energy from the power station

Understanding Distribution Boxes: A Comprehensive Guide

A distribution boxes is an essential device that manages the safe and efficient flow of electrical power throughout different areas of a building or facility.



The Complete Guide to Distribution Box: Installation, Types & More

What's the difference between a distribution box and a sub-panel? A distribution box typically refers to the main electrical panel that receives power from the utility service. A sub-panel is

Distribution Boxes Types - The Complete Guide

The power distribution boxes deliver electricity from the main electrical main to other circuits. Several distribution boxes are designed for specific use in

Distribution Box Guide: Types, Components & Solutions

Understand distribution boxes (DB boxes) in 5 minutes. Learn about types, components, functions, and uses. Find the perfect DB box for your needs.



Explore Power Distribution Box Types and Functions

Power distribution boxes are used in commercial and residential buildings and are part of the electrical system, also known as switchboards.

Understanding Distribution Boxes: A Comprehensive Guide

A distribution box, also known as a power distribution box or electrical distribution box, is used to distribute electrical power safely to multiple

The installation requirements for the distribution



box

A distribution box is the heart of any electrical system. It takes the incoming power and safely distributes it to different circuits throughout your

What is an Electrical Distribution Box? A

The distribution box helps distribute load evenly across different circuits, preventing overload. Protects Against Short Circuits and Surges: With

The Complete Guide to Distribution Box: Installation, Types & More

Blog The Complete Guide to Distribution Box: Installation, Types & More By Admin Aug 2, 2025 No Comments # distribution box Introduction Electrical systems power our homes, offices, and



Distribution Board vs. Distribution Box: What's the

What is a Distribution Box? A distribution box is a compact electrical enclosure designed to help safely manage local power distribution. It doesn't

CHINT Distribution box PZ30-15 Ning assembly power 1mm Selling

Constructed with a 1mm thick steel frame, this distribution box ensures robust protection for electrical systems in both residential and commercial settings. The compact design provides an efficient and

How Does a Power Distribution Box Work: A Guide



Learn how a power distribution box works, its role in safely managing electricity, and why it's vital for efficiency in industrial and commercial projects.

CHINT Distribution box PZ30-15 Ning assembly power 1mm Selling

The CHINT Distribution Box PZ30-15 Ning Assembly Power 1mm is a durable and compact solution for protecting electrical circuits in homes, offices, and industrial settings. Easy to install and reliable, it

The Importance of Distribution Boxes in Electrical Systems

A distribution box is an exposed or concealed metal box that houses the circuit breakers that regulate the distribution of electricity throughout a



Power Distribution Board: Uses, Role & How its Work

Learn about power distribution boards: their uses, role, and how they work to manage electrical power distribution efficiently and safely in various setups.

Contact Us

For datasheets, pricing, or custom optical networking solutions, please visit:
<https://www.entrenamientointeligente.es>